

# Installation and operating manual

Storm valve

LK product no: 159801/159301



## Contents

<b>1</b>	<b>General information</b> .....	<b>3</b>
1.1	Manual validity .....	3
<b>2</b>	<b>Valve description</b> .....	<b>4</b>
2.1	159301 – Storm valve angle .....	4
2.2	159801 – Storm valve straight.....	5
<b>3</b>	<b>Technical data and scope of application</b> .....	<b>6</b>
3.1	Dimensions.....	6
<b>4</b>	<b>Product marking</b> .....	<b>7</b>
<b>5</b>	<b>Storage and handling instructions</b> .....	<b>8</b>
5.1	Storage .....	8
5.2	Lifting and handling .....	8
<b>6</b>	<b>Installation</b> .....	<b>8</b>
6.1	Installation procedure .....	8
6.2	Bolt tightening sequence.....	8
6.3	Approved installation angles.....	9
<b>7</b>	<b>Maintenance and repair</b> .....	<b>9</b>
7.1	Blockage in the top part of the vertical valve .....	9
7.2	Blockage in the bottom part of the vertical valve.....	10
7.3	Blockage in the top part of the angled valve.....	11
7.4	Blockage in the bottom part of the angled valve .....	11
<b>8</b>	<b>Removing the valve</b> .....	<b>12</b>
<b>9</b>	<b>Spare parts</b> .....	<b>12</b>
<b>10</b>	<b>Contact information</b> .....	<b>13</b>
	<b>Appendix A Bolting torque data</b> .....	<b>14</b>

## 1 General information

Significance of symbols are illustrated below.



### Attention!

Warning of general danger.

This manual shall serve as an instruction for installation and operation of LK Valves storm valves. For technical specifications please see valid data sheet found on LK Valves website ([www.lkvalves.com](http://www.lkvalves.com)).

It is the responsibility of the installer to ensure that approved materials are used and that the installation and maintenance work meets applicable rules, regulations and requirements. National safety requirements and guidelines must be applied and observed both at installation and maintenance, as well as in repair work.

In case of problems that cannot be solved from information in this manual, LK Valves shall be contacted for support.

Note that most of the information in this manual concerns safety, so please read carefully before installation of the valve.

The manufacturer reserves the right to introduce technical modifications at any time.

### 1.1 Manual validity

This manual is valid for the LKV product ranges 159801 and 159301 Storm valves. Including the list of article numbers in table 1.

159301 Storm valve angle		159801 Storm valve straight	
DN	Art.no.	DN	Art.no.
DN50/DN80	36434	DN50	36428
DN65/DN100	36435	DN65	36429
DN80/DN125	36436	DN80	36430
DN100/DN150	36437	DN100	36431
DN125/DN175	36438	DN125	36432
DN150/DN200	36439	DN150	36433

*Table 1 Products included in the manual*

## 2 Valve description

This section outlines the general structure and working principle of the storm valves. 159301 and 159801 Storm valves have rising stem design.

### 2.1 159301 – Storm valve angle

Bill of materials of angle storm valve 159301 is listed in Table 2 with reference to sketch in

Figure 1.

No.	Part	Material
1	Body	Ductile iron EN-JS1030 (GGG40)
2	Disc	Ductile iron EN-JS1030 (GGG40)
3	Disc sealing	NBR
4	Sleeve	Brass CW614N (Ms58)
5	Sealing	NBR
6	Stem	Brass CW614N (Ms58)
7	Shaft	Brass CW614N (Ms58)
8	Spring	Stainless steel 1.4310 (AISI301)
9	Plug	Zinc plated steel
(DN80 and above)	Axial pin	Brass HPB59-1
(DN80 and above)	Hex nut	Brass H62

Table 2 159301 Bill of materials

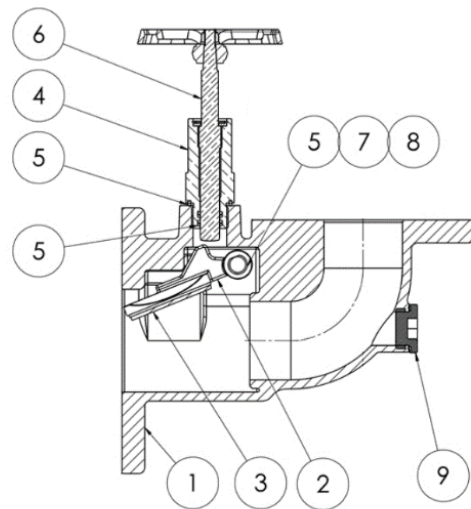

Figure 1 BOM sketch for 159301 angle storm valve

On DN80 and above sizes, an extra joint is added to the disc, with an axial pin and a hexagon nut, the joint is visible in Figure 2.

The normal operating mode and open/closed are illustrated in Figure 2.

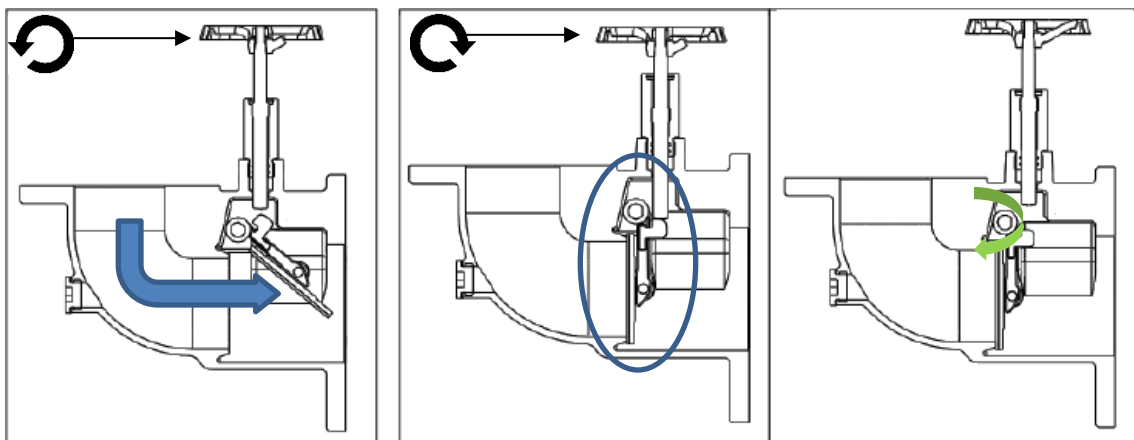

Figure 2 To the left, Storm valve angle in normal working mode. In the middle closed storm valve angle. To the right open storm valve angle under spring load in the direction of the twisted arrow.

The normal working mode of the valve is open with water flowing in the direction of the blue arrow in Figure 2. To open the valve turn the hand wheel counter-clockwise until a stop is felt. To close the valve turn the hand wheel clockwise until a stop is felt.

In open position the valve will act as a spring loaded check valve and open for flow in the direction of the blue arrow, see Figure 2. This while preventing back flow in the opposite direction of the arrow by a spring load, see Figure 2 green arrow, on the disc, which closes the valve when there is no flow in the direction of the blue arrow.

## 2.2 159801 – Storm valve straight

Bill of materials of straight storm valve 159801 is listed in Table 3, with reference to sketch in Figure 3.

No.	Part	Material
1	Body	Ductile iron EN-JS1030 (GGG40)
2	Disc	Ductile iron EN-JS1030 (GGG40)
3	Disc sealing	NBR
4	Sleeve	Brass CW614N (Ms58)
5	Sealing	NBR
6	Stem	Brass CW614N (Ms58)
7	Shaft	Brass CW614N (Ms58)
8	Spring	Stainless steel 1.4310 (AISI301)
9	Plug	Zinc plated steel
(DN80 and above)	Axial pin	Brass HPB59-1
(DN80 and above)	Hex nut	Brass H62

Table 3 159801 Bill of materials

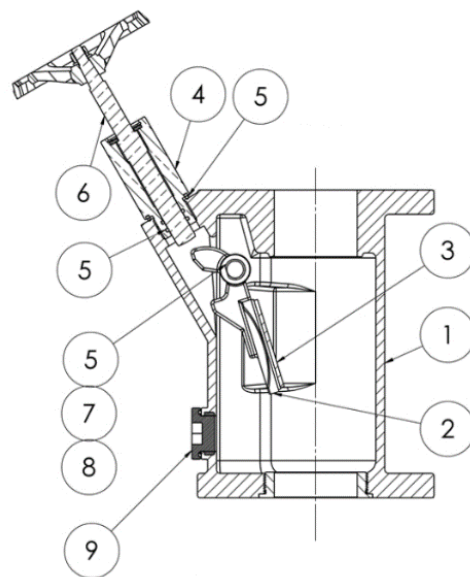
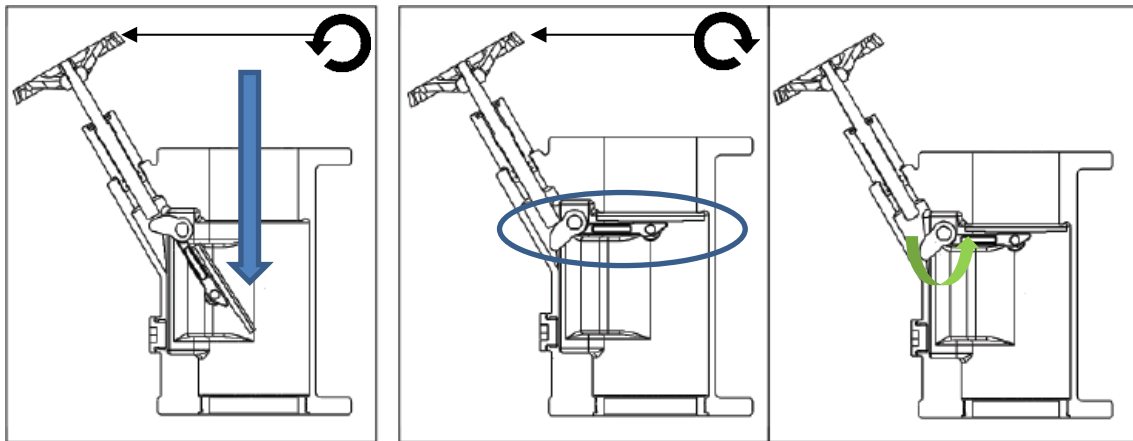

Figure 3 BOM sketch for 159801 straight storm valve

On DN80 and above sizes, an extra joint is added to the disc, with an axial pin and a hexagon nut, the joint is visible in Figure 4.

The normal operating mode and open/closed are illustrated in Figure 4.



*Figure 4 To the left, Storm valve straight in normal working mode. In the middle closed storm valve straight. To the right open storm valve straight under spring load in the direction of the twisted arrow.*

The normal working mode of the valve is open with water flowing in the direction of the blue arrow in Figure 4. To open the valve turn the hand wheel counter-clockwise until a stop is felt. To close the valve turn the hand wheel clockwise until a stop is felt.

In open position the valve will act as a spring loaded check valve and open for flow in the direction of the blue arrow, see Figure 4. This while preventing back flow in the opposite direction of the arrow by a spring load, see Figure 4 green arrow, on the disc, which closes the valve when there is no flow in the direction of the blue arrow.

### **3 Technical data and scope of application**

The valves are designed for working pressure of maximum four (4) Bar. Primary application of the valves is discharge of sewage water on marine vessels. The storm valves are designed to open above a pressure corresponding to 1L of water.

#### **3.1 Dimensions**

Dimensions outlined in this manual references hand wheel in “open” position. For basic dimensions of straight and angled storm valves, see Figure 5 and Table 4.

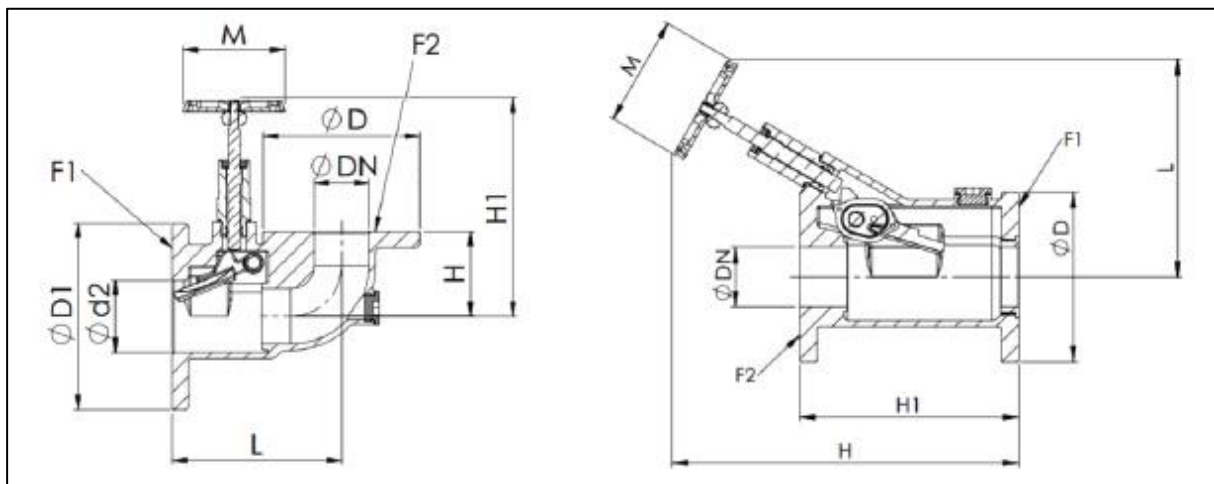

Figure 5 To the left, Storm valve angle dimension reference sketch. To the right, storm valve straight dimension reference sketch.

Item no.	DN	Pressure rating	Connection flange 1 (F1)	Connection flange 2 (F2)	L	D	D1	D2	H	H1	M	Weight (kg)
<b>159301 - Angle - PN10/16 connection</b>												
36434	50	PN 4	Ø160xØ19x8	Ø125xØ19x4	180	165	200	68	90	247	120	11,7
36435	65	PN 4	Ø180xØ19x8	Ø145xØ19x4	200	185	220	85	100	255	120	14,3
36436	80	PN 4	Ø210xØ19x8	Ø160xØ19x8	215	200	250	100	108	256	120	17
36437	100	PN 4	Ø240xØ23x8	Ø180xØ19x8	250	220	285	130	130	311	140	23,4
36438	125	PN 4	Ø270xØ22x8	Ø210xØ19x8	290	250	315	158	152	322	140	29,3
36439	150	PN 4	Ø295xØ23x8	Ø240xØ23x8	330	285	340	190	176	334	140	35,5
<b>159801 - Straight - PN10/16 connection</b>												
36428	50	PN 4	Ø125xØ19x4	Ø125xØ19x4	223	165	-	-	330	200	120	10,8
36429	65	PN 4	Ø145xØ19x4	Ø145xØ19x4	232	185	-	-	369	240	120	13,9
36430	80	PN 4	Ø160xØ19x8	Ø160xØ19x8	263	200	-	-	416	260	140	16,9
36431	100	PN 4	Ø180xØ19x8	Ø180xØ19x8	271	220	-	-	428	300	140	21,2
36432	125	PN 4	Ø210xØ19x8	Ø210xØ19x8	284	250	-	-	475	350	140	27,9
36433	150	PN 4	Ø240xØ23x8	Ø240xØ23x8	304	285	-	-	530	400	140	35,1

Table 4 Dimensions including flange drillings

Note that the angle storm valve has different flanges on horizontal and vertical faces.

Maximum allowed torque for opening/closing of valve is **10Nm**, which must not be exceeded.

## 4 Product marking

Each valve is marked with:

- Pressure rating: PN4
- Flow direction
- Valve DN size
- Charge no.

## 5 Storage and handling instructions

### 5.1 Storage

Store the valves indoors in a clean and dry place. Corrosion that occurs during storage will significantly reduce the life span of the valve.

High temperature and direct sunlight will shorten the service life of the rubber liner on the disc. Optimal storage condition is in covered pallets with ambient temperature of 5-20°C.

### 5.2 Lifting and handling

Be careful when lifting the valve. Never lift by the valve handle, gear operator, hand wheel or actuator. Securely place the rope, hoist or other lifting equipment around the valve body while handling.

Consider center of gravity and prevent tilting and rotational forces.



## 6 Installation

The valves should never be installed where service conditions could exceed the valve ratings concerning pressure, temperature or operating media. Failure to comply with this warning may result in personal injury or property damage. Valve hand wheels are not designed to take external forces e.g. they must not be used for as climbing aids or as connection of lifting gear.



### 6.1 Installation procedure

Keep stem threads and shaft free from paint if extra paint is added during the installation process. Use only counter flanges and screws with correct dimensions, see paragraphs 3.1 and Appendix A. When installing please take great care to tighten bolts according to sequence given in paragraph 6.2 and. Please note installation positions with reference to flow and marking arrow on valve and center gaskets between flanges.

### 6.2 Bolt tightening sequence

In order to maintain a good sealing between the valve and connecting flanges the connecting bolts must be tightened in correct order, see Figure 6.

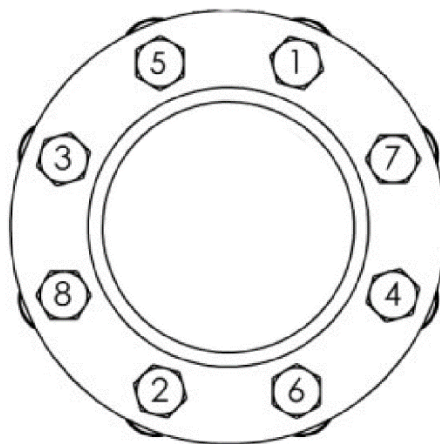

Figure 6 Bolt tightening sequence chart.



Crosswise bolt tightening to ensure a fixed installation, other bolt tightening may affect the installation. Bolt torque is given in paragraph Appendix A, for 8.8 bolts. The procedure should be repeated 2-3 times, to get an even force distribution on the sealing surfaces.

### 6.3 Approved installation angles

The storm valves have been designed to work in any angle. Flow direction must follow marking on the valves for function of the valves to be intact.

## 7 Maintenance and repair

The valves are designed to minimize the required maintenance. If the valves should experience blockage in some part please see below figures for cleaning instructions. Before performing any maintenance on the valves, make sure to read through the installation and removing procedures, safety recommendations and always follow local safety rules and regulations. If any sealings or threads are exposed in the maintenance, they should be treated with care as to not be damaged during handling and inspected for damage before installation.

*When replacing or re-installing plugs on the storm valves, pos. 9 in*

Figure 1& Figure 3, tightening torque to be used is **338Nm**.

For any other issues regarding maintenance and repair, please contact LK Valves directly for technical support, for contact information, see paragraph 9. For a typical installation of storm valves, see Figure 7.

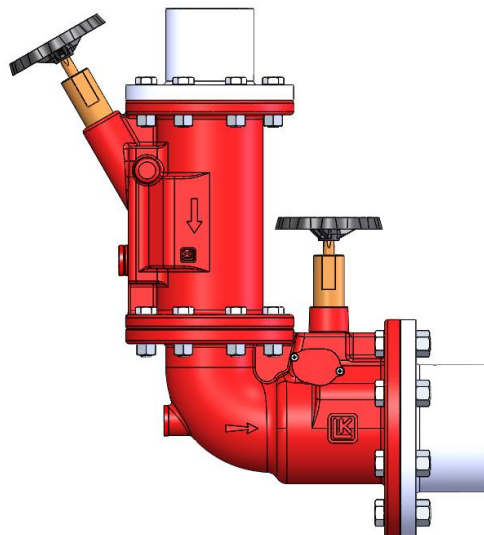

*Figure 7 Typical installation assembly for storm valves.*

### 7.1 Blockage in the top part of the vertical valve

If there is blockage in the top part of the vertical valve, see Figure 8.

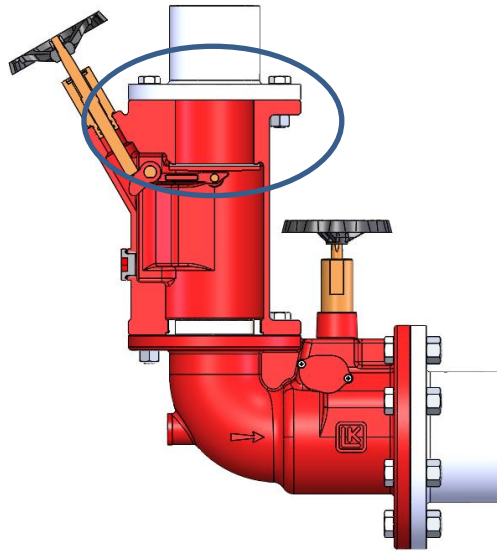
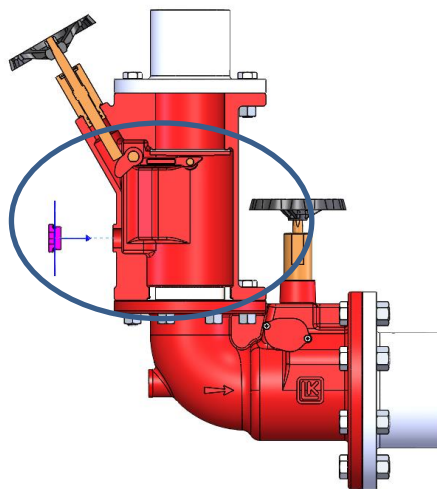

*Figure 8 Top part of straight storm valve.*

Put the valve in open mode by turning the hand wheel counter clockwise until stop. Close any entrance above the straight storm valve to prevent water flow. After the system is blocked in both directions, please remove the valve, take out whatever is blocking the flow and assemble it back in line.

### **7.2 Blockage in the bottom part of the vertical valve**

If there is blockage in the bottom part of the vertical valve, see Figure 9.

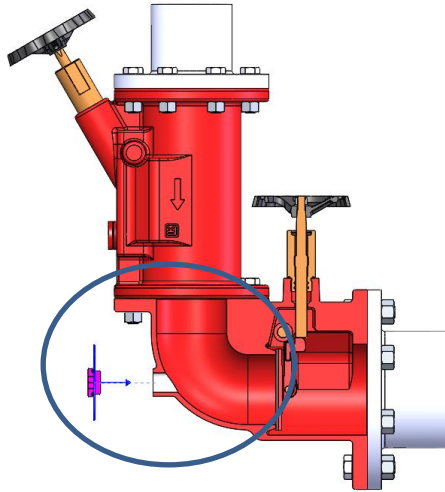

*Figure 9 Bottom part of straight storm valve with removed G7/8" plug.*

Close the vertical valve by turning the hand wheel clockwise until stop. After the valve is closed, remove the G 7/8" plug. After the plug is removed a water jet fitting can be attached using the G 7/8" thread and the valve can be rinsed. If no water jet is available the valve can be rinsed manually. When rinsing, please make sure that the bottom, angle valve, is open so as to allow the fluid and blockage to flow through the system.

### 7.3 Blockage in the top part of the angled valve

If there is blockage in the top part of the angled valve, see Figure 10.

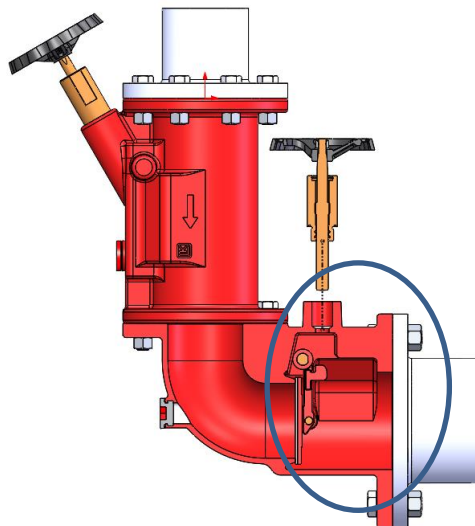

*Figure 10 Top part of angled storm valve with removed G7/8" plug.*

Close the vertical valve by turning the hand wheel clockwise until stop, and make sure that the angled valve is open by turning its hand wheel counter clockwise until stop. After the valves are closed, remove the G 7/8" plug in the angled valve, see Figure 10. After the plug is removed a water jet fitting can be attached using the G 7/8" thread and the valve can be rinsed. If no water jet is available, the valve can be rinsed manually.

### 7.4 Blockage in the bottom part of the angled valve

If there is blockage in the bottom part of the angled valve, see Figure 11.



*Figure 11 Bottom part of angled storm valve with removed stem sleeve, G7/8" thread.*

Close the top vertical valve by turning its hand wheel clockwise until stop. Remove the stem sleeve by turning it counter clockwise, see Figure 11, take care not to damage any sealings or threads. After the

sleeve is removed a water jet fitting can be attached using the G 7/8" thread and the valve can be rinsed. If no water jet is available, the valve can be rinsed manually.

If it is not possible to remove the blockage by rinsing, close the system in both directions, before and after the valve, please remove the valve, take out whatever is blocking the flow and assemble it back in line. When installing the sleeve after maintenance please use waterproof Anaerobic adhesive to fasten the sleeve thread. If no suitable adhesive is available, please use Thread seal tape to fix the sleeve.

## 8 Removing the valve

Prior to any replacement, the valves must be dismantled from the pipe system as follows:

1. Drain and depressurize the pipe on each side of the valve.
2. Before re-installation of the valve please look through the installation instructions.



## 9 Spare parts

When performing maintenance on the storm valves some parts might need replacement due to natural wear or other circumstances. For available spare part kits, see Table 5.

LKV Art.no.	Description	Valid for sizes
95405	Spare part kit1, containing replacement sleeve and plug	Storm valve angle DN50-DN80 Storm valve straight DN50-65
95408	Spare part kit2, containing replacement sleeve and plug	Storm valve angle DN100-150 Storm valve straight DN80-150

*Table 5 List of LKV spare parts.*

Spare part kits acc. to Figure 12.



*Figure 12 Storm valve spare part kit.*

If the need should arise to replace shaft, closing spring and/or disc, please contact LK Valves for support.

## 10 Contact information

These Storm valves are designed and manufactured by LK Valves AB with head office in Sweden where you will also get technical and commercial support.

### **LK Valves AB**

Garnisonsgatan 19  
SE-254 66 Helsingborg  
SWEDEN

Phone: +46 (0)42 383870

Fax.:+46 (0)42 383875

E-mail: [sales@lkvalves.com](mailto:sales@lkvalves.com)

Website: <http://www.lkvalves.com>

## Appendix A Bolting torque data

Bolts used for installing valves should be installed with torque from Table 6.

Thread size	8.8
M5	5,7
M6	9,8
M8	24
M10	47
M12	81
M16	197
M20	385
M24	665
M30	1310
M36	2280
UNC	8.8
1/4 - 20	11
5/16 - 18	22
3/8 - 16	38
7/16 - 14	61
1/2 - 13	93
9/16 - 12	133
5/8 - 11	183
3/4 - 10	322
7/8 - 9	516
1 - 8	772
1 1/8 - 7	1090
1 1/4 - 7	1530
1 1/2 - 6	2650

*Table 6 Bolt tightening torque.[Nm]*

Correct choice of bolt material and coating is up to the installer to choose with account to environmental conditions.