

# Installation and operating manual

## GC Unit

LK product no: GC 1-3

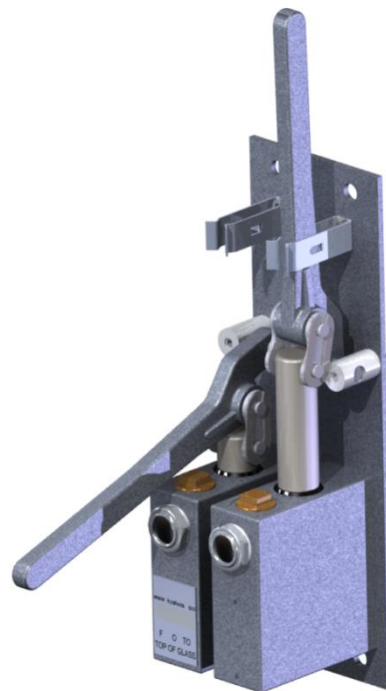



## Contents

<b>1. General information .....</b>	<b>5</b>
<b>2. Safety precautions .....</b>	<b>5</b>
2.1 Significance of symbols .....	5
2.2 Explanatory notes on safety information.....	5
<b>3. Safety instruction.....</b>	<b>6</b>
<b>4. Technical data .....</b>	<b>6</b>
4.1 Hydraulic oil recommendation.....	6
4.2 Sealing .....	6
<b>5. Description of function.....</b>	<b>6</b>
5.1 System design.....	6
<b>6. Options available .....</b>	<b>6</b>
6.1 Header tank.....	7
6.2 Manifolds .....	7
6.3 GC2/25B .....	7
<b>7. Storing and Transport .....</b>	<b>8</b>
<b>8. Location of cabinet .....</b>	<b>8</b>
<b>9. Installation .....</b>	<b>8</b>
9.1 GC unit installation .....	8
9.2 Cabinet installation, for cabinet mounted GC-units only.....	9
<b>10. Putting into operation.....</b>	<b>10</b>
<b>11. Testing of function.....</b>	<b>10</b>
<b>12. Operating instructions.....</b>	<b>11</b>
<b>13. Maintenance instructions.....</b>	<b>11</b>
13.1 Function testing .....	11

<b>14. Troubleshooting scheme .....</b>	<b>12</b>
<b>15. Service kits .....</b>	<b>13</b>
<b>16. Contact info .....</b>	<b>13</b>

## 1. General information

This manual gives instructions on installation of the Hydraulic Control Station together with maintenance recommendations and shall be read carefully before installation is started.

It is in the responsibility of the installer to ensure that the work is carried out in a satisfactorily manner, approved materials are used and that the installation meets applicable rules and regulations. Regional safety requirements must be applied and observed both at installation and maintenance as well as in repair work

It is the installer/owners responsibility to define responsibility and competence of personnel for the installation and maintenance of the valves. In case of problems which cannot be solved from information in this manual the supplier of the valves shall be contacted. The notes and warnings defined in following chapters must be followed as this information concerns your safety.

Note! Part numbering (..) in chapter 6.3 Part list are maintained and used as references through all chapters.

The manufacturer reserves the right to introduce technical modifications at any time.

## 2. Safety precautions

### 2.1 Significance of symbols



Warning of general danger.

### 2.2 Explanatory notes on safety information

In these Operating and Installation Instructions dangers, risks and items of safety information is highlighted to attract special attention.

Information marked with the above symbol and "*ATTENTION!*" describes practices, a failure to comply with which can result in serious injury or danger of death for users or third parties or in material damage to the system or the environment. It is vital to comply with these practices and to monitor compliance.

All other information not specifically emphasised such as transport, installation, operating and maintenance instructions as well as technical data (in the operating instructions, product documentation and on the device itself) must also be complied with to the fullest extent in order to avoid faults which in turn can cause serious injury to persons or damage to property.

### 3. Safety instruction

- Be aware of the fact that the stem with related components (hand wheel) on the QCV will fall down very rapidly by spring force at closing of the valve.
- Avoid injury by always secure the release system when work is carried out on the valve. When testing the remote release system, stay away from moving parts on the valve.
- Loosening any part under system pressure can cause injury.

### 4. Technical data

#### 4.1 Hydraulic oil recommendation

At normal conditions we recommend hydraulic oil in accordance with the specifications below. Use of other media, it is the installers fully responsibility to assure the function of the GC-system.

Viscosity:	at 40°C approx. 15 Cst
Viscosity index:	approx. 150
Pour point:	approx. -45°C
Anti wear additive:	to be added.
For arctic conditions:	use oil corresponding to international specifications MIL-H-5606 B
Oil volume:	26,5 cm <sup>3</sup> .

#### 4.2 Sealing

The GC25B-unit has O-ring seals. In case of excessive heat, make sure that these have not been damaged. If so is the case; replace.

### 5. Description of function

#### 5.1 System design

Each release handle can control a single valve or a group of maximum 6 valves. The design of the control system and dividing of the control handle groups are in the responsibility of the system designer.

### 6. Options available

- Pipe fittings for outlet connections
- Special signs
- Cabinet in mild or stainless steel.
- Header tank 1,4 litres article no 70078
- Distribution Manifolds 2 – 6 connections
- Shuttle valves

### 6.1 Header tank

When a system has a quick closing valve or more placed above the GC unit there is a need of a header tank to avoid emptying the system of oil. The oil level glass (4) is replaced with an angel fitting for connection with the higher located tank. The oil filling plugs in the GC units has to be replaced with an undrilled plug and proper sealing. (For dimensions, see table in GC-2 Left and front view)

### 6.2 Manifolds

In the event that two GC units are connected to the same valve for closing from different locations the system must be equipped with a shuttle valve to direct oil flow to the valve.

### 6.3 GC2/25B

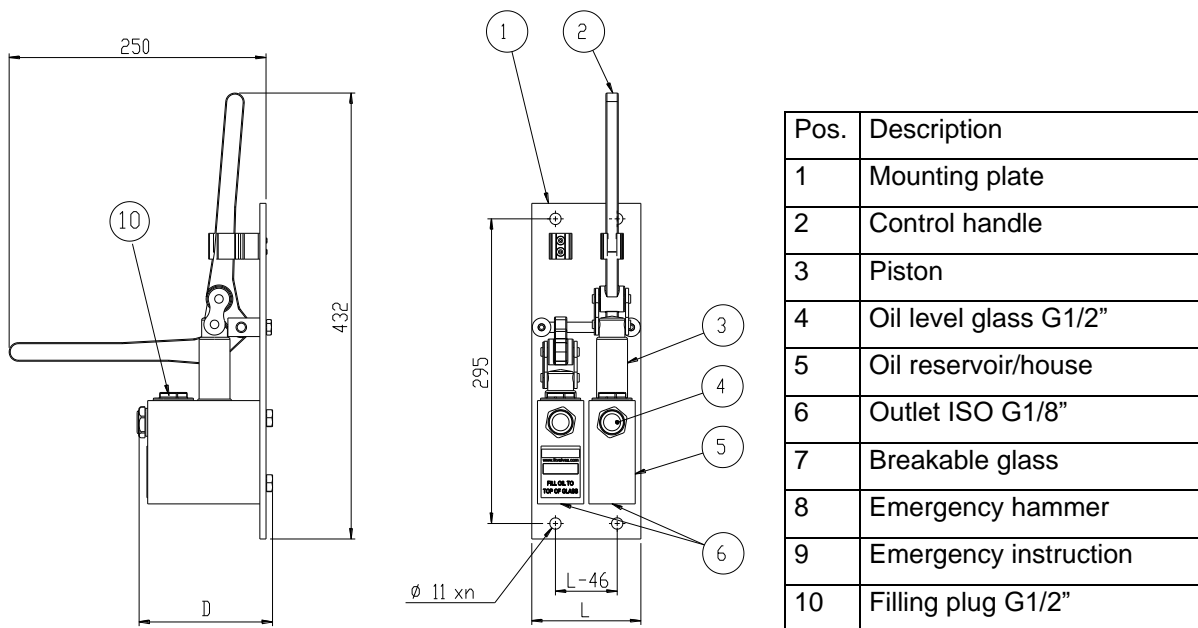

#### GC- 2 Left and front view

	L	D	H	Weight (Kg)	Cabinet included
GC25B-1	60	121	437	3,1	16
GC25B-2	106	121	437	6,3	18,5
GC25B-3	156	121	437	9,4	21



### Attention!

Protect the GC-unit and cabinet against external forces. To avoid loading at the glass window the cabinet shall be transported in standing position. For lifting, use suitable soft handling equipment to avoid damage on painted surfaces.

## 7. Storing and Transport

- The GC-unit shall be stored indoors well protected from dust and moisture.
- Long time storing must be done in warm warehouses to avoid corrosion on unprotected surfaces.
- Plastic protection covers fitted to pipe connection threads (6) are not to be removed until pipe assembly.

## 8. Location of cabinet

The cabinet shall be located in a space which has a good protection in event of fire and in easy reach for emergency closing of the valves.

## 9. Installation

All installation of the GC-unit must be done by authorized personnel.

### 9.1 GC unit installation

The connecting pipes (connected to pos 6) from the GC-unit to the valve or groups of valves shall be minimum metric 6x1 steel tubes or corresponding inch diameter.

The pipes must be properly cleaned and burrs must be removed before mounting.

The pipes must be installed with continuous inclination towards the GC unit to ensure proper function; this will even ease venting the system. Excessive piping will multiply the possibility of air pockets; keep the piping as short as possible.

To avoid thermal expansion of the oil do not place the pipes close to warm areas or areas with big temperature differences.



### **Attention!**

Continuous inclination from QCV to GC units is essential to bleed the system from air and secure proper function.



**9.2 Cabinet installation**, for cabinet mounted GC-units only

The cabinet is fixed to the bulkhead or wall by screws in the holes in the back of the cabinet.

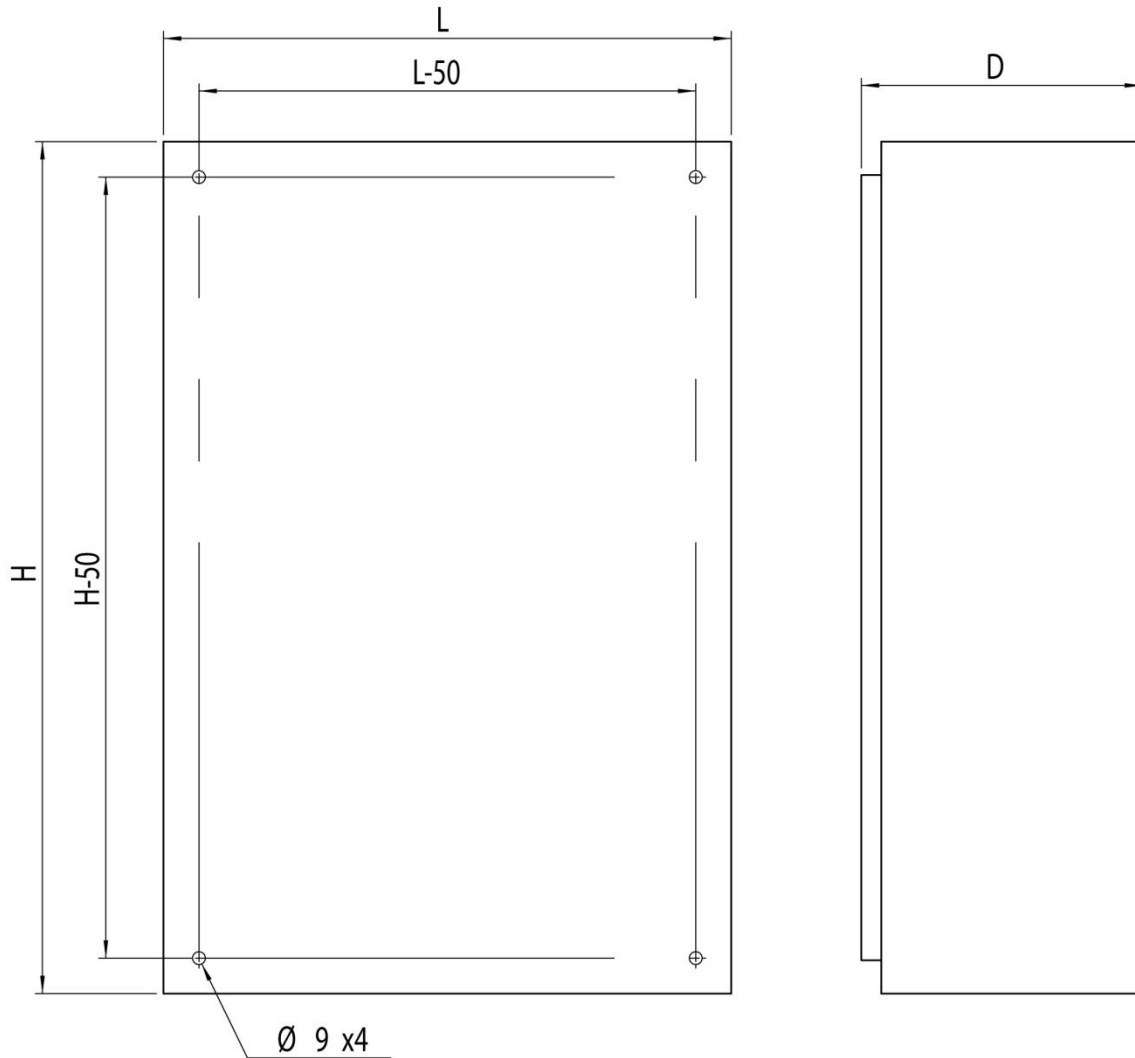

**Cabinet Back and right view**

	L	D	H	Stainless steel (Kg)
GC-1	400	200	600	16
GC-2	400	200	600	18,5
GC-3	400	200	600	21
GC-4	400	200	600	24
GC-5	600	200	600	29
GC-6	600	200	600	32

## 10. Putting into operation

- Put the lever (2) of the GC25B unit upright position until they are fixed by the clamp.
- Fill the reservoir (5) with oil until the oil level is on top of the indicating glass (4).
- For some applications or when the GC25B unit is located below the highest placed quick closing valve a header tank must be included in the system. When including a header tank, the plug on the reservoir top must be replaced with a plug without venting hole. All filling of oil must be via the header tank.
- Loosen the pipes from the release cylinders, one at the time, and let the oil flow until it is clear and free from all air.
- If the pipes do not have an even inclination, venting can be eased by filling the pipe from the valve-end side with a pump.
- Keep filling the reservoir (5) with oil during the filling process.
- Before connecting the pipes to the release cylinders, fill the cylinder with oil.
- Check piping system for leakage.
- Put the control handles (2) in position open.
- Reset the quick closing valves to open position. This is done by using the hand wheel on the top of the quick closing valve. See quick closing valve; Installation and Maintenance manual.

## 11. Testing of function

- Make sure all control handles (2) are in upright position and fixed by the clamp.
- **Be assured that the system is filled with oil and bled for air.**
- Check the oil level (4) in the reservoir (5).
- Check that all Quick Closing Valves are loaded and in open position.
- Operate each control handle (2) and check that corresponding quick closing valve or valves will close.



### Attention!

Make sure before testing, or in any way interrupt the function of the quick closing valve system, it will not affect the safety arrangements for the ship.



### Attention!

Be aware of the fact that the hand wheel on the quick closing valve will fall down very rapidly when the release cylinder on the quick closing valve is pressurized.  
When testing, stay away from moving parts on the valve.

## 12. Operating instructions

In an emergency situation follow the instruction sign located on the GC25B unit.

For GC25B units with a cabinet and emergency hammer, break the window.

For cabinets without emergency hammer, use the key and open the door.



### Attention!

When the glass window has been broken remove all sharp glass pieces before putting the hands inside the cabinet.

### 12.1 Operating with LK Valves Quick closing valves

When operating with LK Valves Quick closing valves the lever should be subjected to a pulling force of 375N at a distance of 35mm from the edge of the lever to ensure actuation of the LK Valves release unit. When pulling the lever the operator will feel the piston moving and stopping when the valve is actuated which can occur at lower forces than 360N. The force must not exceed 440 N, as to not damage the release cylinder. The operating range to ensure that the release unit will have enough force to open is 25-30 Bar and must not be exceeded.

## 13. Maintenance instructions

The system requires no maintenance, but the following recommends to be checked at regular intervals:

- Clean and check the piston (3) for heavy scratches.
- Check the clamp ability to fix the control handle, adjust if necessary.
- Check the level of oil in the reservoir, refill if necessary.

### Note

Intervals for inspection of the GC25B units can vary depending on the environment. The inspection can be scheduled after experience or after recommendations from the classification society, other authorities or the ship owner.

### 13.1 Function testing

At regular intervals or at a classification survey check the function of the system.



**Attention!**

When testing the system, be sure that the closing of valves will not cause any disturbance for the function of the ship.

**14. Troubleshooting scheme**

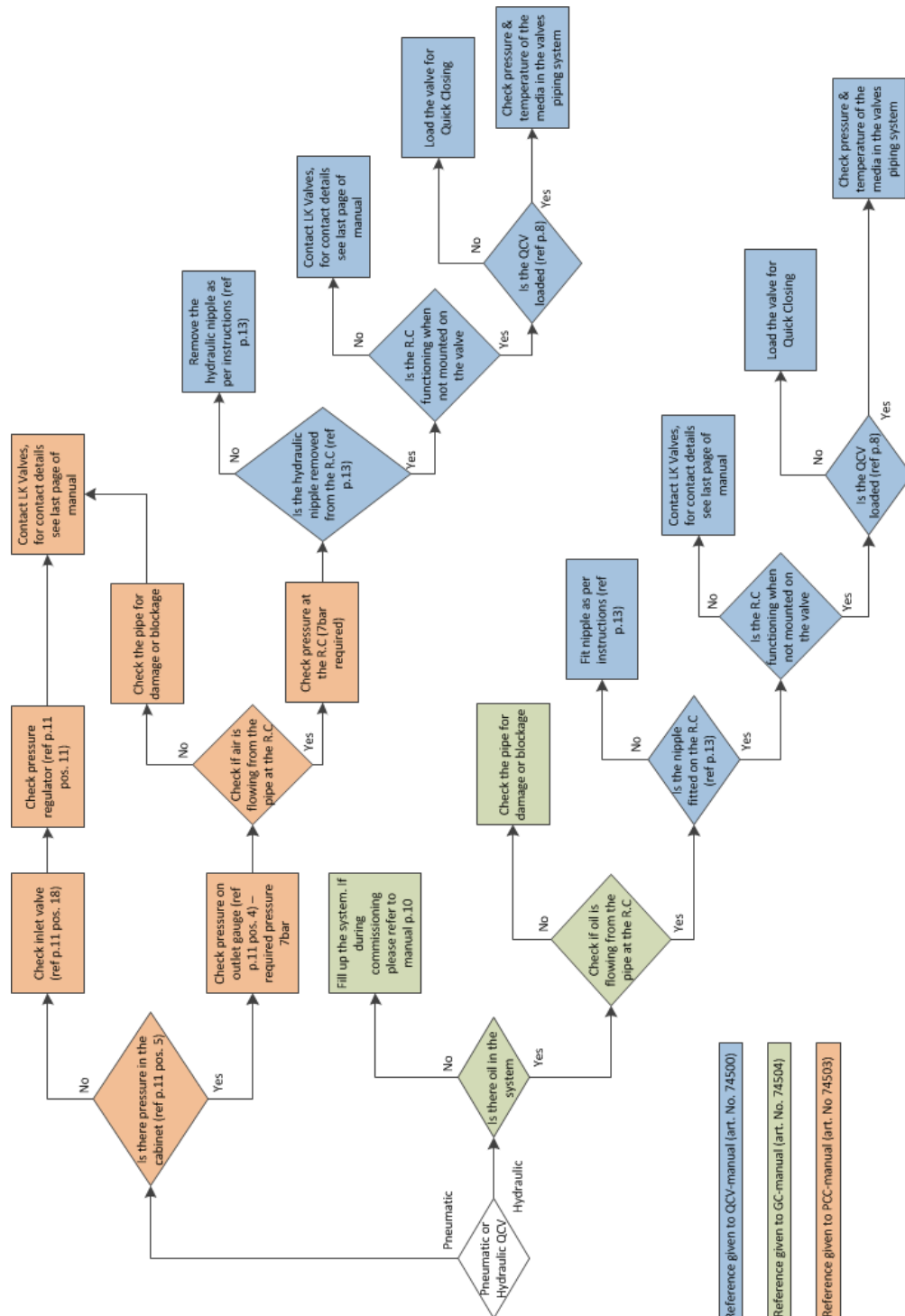

## 15. Service kits

Repair kits are available. For replaceable articles, please contact LK Valves.

<b>Repair kit</b>	<b>Article no.</b>	<b>Contents</b>
Spare part kit1 GC25/B	92380	72430 – 2 pcs O-ring 70074 – 1 pc Level sight glass 72423 – 1 pc Wiper seal
Spare part kit2 GC25/B	92381	72419 – 1 pc Lever 70060 – 1 pc Chain link 70059 – 1 pc Clamp 70648 – 2 pcs Set screw MSK6SS 72293 – 2 pcs Screw MC6S
Spare part kit1 GC30/A	92382	70531 – 2 pcs O-ring 70074 – 1 pc Level sight glass 70085 – 1 pc Scraper
Spare part kit2 GC30/A	92385	70057 – 1 pc Lever 70060 – 1 pc Chain link 70059 – 1 pc Clamp 70821 – 2 pcs Set screw MSK6SS 72293 – 2 pcs Screw MC6S

## 16. Contact info

LK Valves AB  
Garnisonsgatan 19  
SE-254 66 Helsingborg  
SWEDEN

Telephone: +46 (0)42 38 38 70  
Fax: +46 (0)42 38 38 75

Website: <http://www.lkvalves.com>  
E-mail: [sales@lkvalves.com](mailto:sales@lkvalves.com)